

AirLine & AirLine LED

Inline axial extract fan systems for shower cubicles

Domestic



Clearing excess steam in the bathroom is no longer a problem with the Xpelair Airline and its perfectly optimised impeller design. It gives you high-level performance and meets Building Regulations Part F – even when installed with ducting and an external grille. The AirLine system also has the benefit of being installed up and out of the splash zone in the loft, helping to keep noise levels to a minimum.

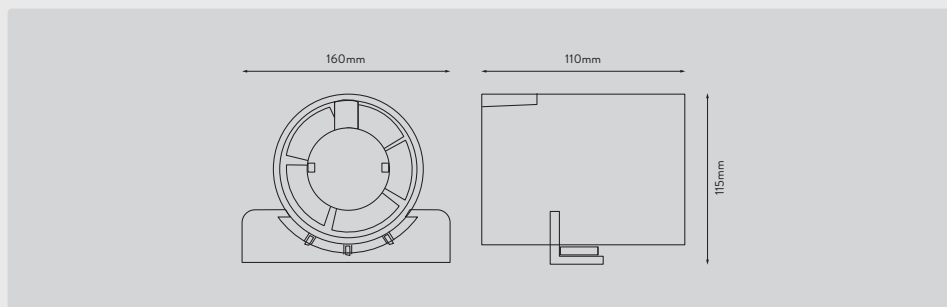

Product Features	AL100	AL100T	ALL100	ALL100T
Reference Number	93288AW	93289AW	93290AW	93291AW
Standard	✓		✓	
Timer (adjustable 2 – 30mins)		✓		✓
Integrated LED Light			✓	✓

Product Selector	AL100	AL100T	ALL100	ALL100T
Reference Number	93288AW	93289AW	93290AW	93291AW
Electrical Power Rating (W)	16	16	19	19
Extract Performance (FID, m ³ /h)	85	85	85	85
Extract Performance (FID, l/s)	24	24	24	24
Sound Pressure Level (dBA@3m)	40	40	40	40
Duct Diameter (mm)	100	100	100	100
IP Rating	IPX4	IPX4	IPX4	IPX4
UK Guarantee (Years)	2	2	2	2

Bulb Specification (ALL100/ALL100T only)	
Colour	Cool white
Colour Temperature (Kelvin)	6780
Lumens (Lm)	120
Power (W)	3
Expected Life (Hours)	50,000
Expected On/Off Cycles	5,000

AirLine AL100 & AL100T Supplied With:

- AL100 / AL100T inline extract fan
- White bezel
- Chrome bezel
- White external grille
- 3M flexible ducting
- Fixings

AirLine LED ALL100 & ALL100T Supplied With:

- ALL100 / ALL100T inline extract fan
- White bezel with integrated LED
- Chrome bezel with integrated LED
- White external grille
- 3M flexible ducting
- Fixings
- SELV transformer

