

envirovent[®]



Lifetime
Range[™]

PIV LoftVent Mk2 Positive Input Ventilation

Whole House Ventilation



PIV LoftVent Mk2

Whole House Positive Input Ventilation



About

The EnviroVent Loft Mounted Unit is a sophisticated whole house ventilation and condensation control unit for homes with a loft space. The unit gently ventilates the home from a central position on the landing in a house or the central hallway in a bungalow to transform a stagnant and stale atmosphere into a fresh, healthy and condensation free environment.

Features & Benefits

- ▶ Superior long life filters
- ▶ Ultra Low Watt DC motor technology
- ▶ Integral Hours Run Meter (as standard)
- ▶ Integral intelligent comfort heater (LV2-EVL-H only)
- ▶ 3 year warranty
- ▶ Quiet operation
- ▶ Reduces/eliminates surface condensation
- ▶ Eliminates mould
- ▶ Stops streaming windows
- ▶ Removes musty odours
- ▶ Improves air quality
- ▶ Enhances heat distribution
- ▶ Takes advantage of the benefits of solar gain



Energy Saving Benefits

✔ Minimum Energy Consumption

Powered by an Ultra Low Watt Brushless DC Motor, the EnviroVent PIV Loft Mounted Unit utilises the latest technology to ensure minimum energy consumption and long term trouble free life.

✔ Solar Gain

The unit takes maximum advantage of the benefits of solar gain from within the loft space - the natural accumulation of heat from the sun on bright days. Temperatures in the loft space are on average 3°C higher than outside, using this warmer air results in a relative saving of around 150 Watts per day in an average family home. This equates to approximately 10% of annual heating costs.

✔ Heat Distribution

Warm air accumulates at ceiling level. This air can be up to 7°C higher than the internal air at ground level. By introducing an almost imperceptible air supply into the dwelling from the loft space, the PIV Loft Mounted Unit helps to redistribute heat around the home and thus reduce space heating costs.

✔ No Need to Open Windows

To reduce humidity and condensation during the heating season, significant energy loss occurs by opening windows. By installing a PIV Loft Mounted Unit and providing fresh filtered air to the home, humid air is displaced without opening windows and thus making significant savings to the occupier.



Health Benefits

With improved building features in our homes, such as cavity wall insulation, double glazing and draught proofing, 'natural ventilation' is prohibited. Stale air is trapped causing streaming windows, which ultimately leads to musty smells, dampness and mould growth. These mould spores are known allergens and become airborne at the slightest disturbance.

The microscopic spores are then inhaled and can trigger respiratory problems such as asthma, dust allergies and hayfever. The PIV Loft Mounted Unit draws air into the dwelling from outside and filters it before being delivered into the property. Moisture-laden air is diluted, displaced and replaced with clean, tempered and filtered air. This eliminates or reduces surface condensation, which causes mould growth, providing a significant improvement in the health of asthma sufferers and general indoor air quality.



✓ Low Life-cycle Costs

With 3 year on-going maintenance free warranties and superior long life filters the unit achieves the lowest life-cycle costing. All repairs, maintenance and component replacement is carried out simply and quickly by exchanging the filters.

✓ Comfort Heater & Hours Run Meter

The integral comfort heater is designed to temper the incoming air during periods of low external temperatures. A sensor monitors incoming air and slowly pulses the heater to ensure temperatures are held to pre-set minimums. Two independent safety cut-out devices shut down the heater in the event of fan failure. The heater facility is controlled independently from the fan by a conveniently positioned enable/disable switch. For monitoring of operational life and verification of usage, an integral Hours Run Meter is fitted.

Annual Running Costs

Please scan our QR code to see the **annual running costs** of this product.



Or visit:
[envirovent.com/
annual-running-costs](http://envirovent.com/annual-running-costs)

Comparisons against other household appliances

HOUSEHOLD APPLIANCE	TIME REQUIRED TO CONSUME THE ANNUAL ENERGY USAGE
FRIDGE FREEZER	19.7 DAYS
42" TV (VIEWING TIME)	19.6 DAYS
100W LIGHT BULB	14.3 DAYS
HOME PC	4.6 DAYS
GAMES CONSOLE	4.6 DAYS
IRON	41 HOURS
TUMBLE DRYER	17 HOURS
COLDFILL DISHWASHER	17 LOADS

Annual energy usage with comfort heater disabled.



Technical Specification

Product

Whole house positive input ventilation system for properties with a loft space.

Applications

Sited in a loft space, the unit delivers air to the central hallway or landing via a four-way diffuser with purpose made blanking plates to maximise efficiency of airflow and aid in heat distribution from ceiling level. This provides displacement ventilation in order to improve air quality and resolve condensation related problems.

Performance & Sound Levels (as installed figures)

Incoming Air Temp. (°C)	Fan Speed Setting	Specific Fan Power (SFP)	Airflow (l/s)	Power Usage (W) (4)	Outlet Noise dB(A) @ 3m
<19 (1) (2)	Trickle	0.17	21	4	<15
	Medium	0.15	29	4	<15
	Large	0.16	38	6	<15
	Boost	0.19	49	9	15

- The unit performs in 'condensation control mode' at air temperatures below 19°C
- At above 19°C the unit increases airflow rates per setting by 10%
- The unit will stop running at temperatures above 25c to prevent overheating.
- Power usage with heater disabled

Installation

Full installation guide is enclosed with all products; or sent separately in advance - if required. If installed in dwellings with a floor above 4.5m, LV2-EVL-H or LV2-EVL shall be fitted with a Steel diffuser (contact EnviroVent for specific fire diffuser codes).

Construction

ABS plastic body.

Motor

Incorporates the Ultra Low Watt DC motor technology with sealed for life ball bearings designed to operate continuously at a pre-set 'background' rate.

Fan

Is a Ø146mm dual inlet forward curved centrifugal fan.

Filter

Is a synthetic fibre based filter made to ISO coarse 65% standard in accordance with the ISO 16890 standard, conforming to all European Union and US fire classification standards (e.g. DIN 53438-F1 and UL900-class 2) and be self-extinguishing.



Servicing / Maintenance

Servicing requirements include the replacing of filters, the frequency of maintenance will vary depending on the environment it is kept in. There should be no requirement for other maintenance unless the unit is subject to impact damage.

Warranty

LV2-EVL-H and LV2-EVL are covered by a 3 year supply only warranty. For more details on this please see installation guide.

Integral 'Intelligent Low Temperature' Comfort Heater

During cold periods, the LV2-EVL-H (heater model) is capable of maintaining the incoming air temperature consistently at 10°C. The integral heater element is manufactured in a solid tubular sheath material.

Accreditations

Conforms to the requirements of the UK Building Regulations and the Technical Standards for Ventilation.

Conforms to requirements of the EC council directives

Relating to Electromagnetic Compatibility and Electrical Safety (LDV and EMC). CE Marked.

Performance Curve at Free Air

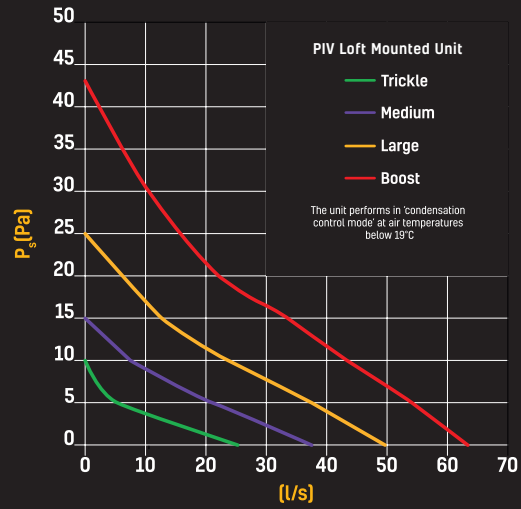

Dimensions (mm)

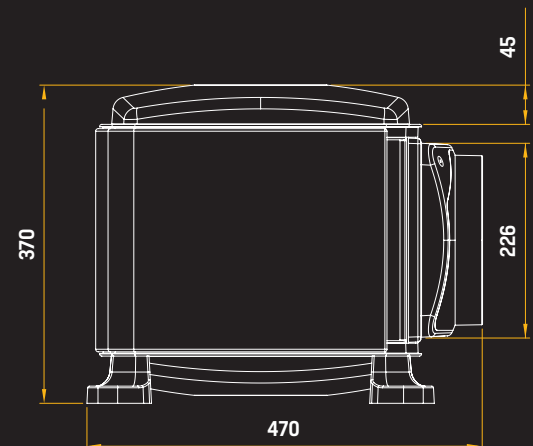
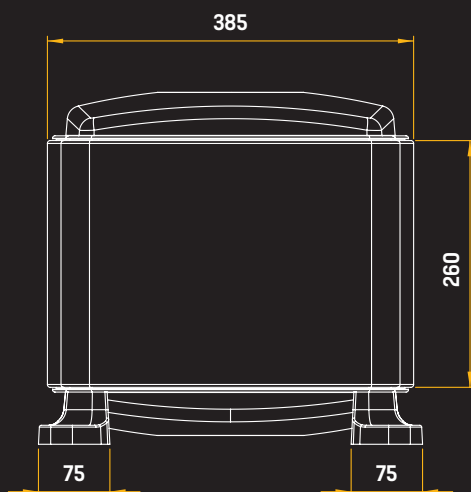
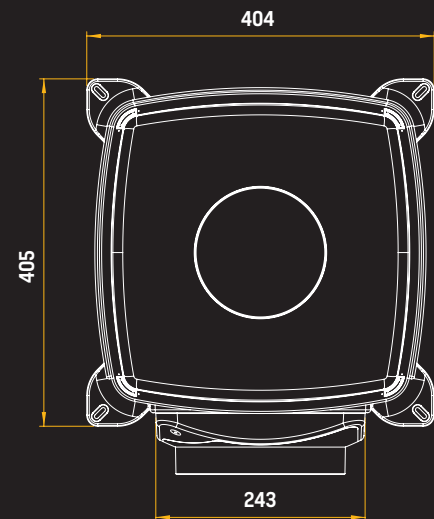
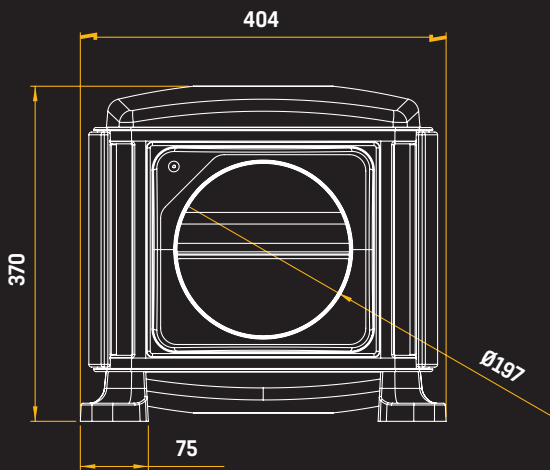

envirovent®

Leaders in the manufacture of innovation and sustainable ventilation

EnviroVent Ltd
Harrogate West Business Park
Unit 1 Bardner Bank
Killinghall, Harrogate
HG3 2SP

T / 01423 810 810
E / enquiries@envirovent.com
W / www.envirovent.com

Due to our policy of continuous innovation and improvement, EnviroVent reserves the right to alter products specification and appearance without notice.

E&OE | MKT ENV1127 - V3 - 11/10/2024

Copyright © EnviroVent Ltd 2024



Follow us on
[facebook](#)



Follow us on
[twitter](#)



Watch us on
[Youtube](#)



Follow us on
[Instagram](#)



Find us on
[LinkedIn](#)

