

TECHNICAL DATA SHEET

PIV LoftVent Mk2 | Whole House Positive Input Ventilation Unit LV2-EVL and LV2-EVL-H



Lifetime Range*



PRODUCT

Whole house positive input ventilation system for dwellings with a loft space.

APPLICATIONS

The whole house PIV Loft Mounted unit shall be manufactured in the UK and installed in dwellings with a loft space to meet local Building Regulations.

SERVICING / MAINTENANCE

Servicing requirements include replacing of filters, the frequency of maintenance will vary depending on the environment the unit is kept in. There should be no requirement for other maintenance unless the unit is subject to impact damage.

PERFORMANCE & SOUND LEVELS AS INSTALLED

Incoming Air Temp. (°C)	Fan Speed Setting	Specific Fan Power (SFP)	Airflow (l/s)	Power Usage (W) (4)	Outlet Noise dB(A) @3m
<19 (1) (2)	Trickle	0.17	21	4	<15
	Medium	0.15	29	4	<15
	Large	0.16	38	6	<15
	Boost	0.19	49	9	15

1. Above 19°C the unit increases airflow rates per setting by 10%.

2. The unit switches to Summer Mode at air temperatures at or above 25°C.

3. Power usage with Comfort Heater disabled.

TECHNICAL DATA SHEET

PIV LoftVent Mk2 | Whole House Positive Input Ventilation Unit LV2-EVL and LV2-EVL-H

INSTALLATION

A full installation guide can be provided or sent separately in advance - if required. For 3 floor properties or properties above 4.5m this unit should be fitted with a steel diffuser (contact EnviroVent for specific fire diffuser codes).

CONSTRUCTION

ABS plastic to contain at least 50% recycled material.

OPTIONAL INTEGRAL INTELLIGENT COMFORT HEATER

During cold periods, the LV2-EVL-H (heater model) is capable of maintaining the incoming air temperature consistently at 10°C. The integral heater element is manufactured in a solid tubular sheath material.

MOTOR

Incorporates the Ultra Low Watt DC motor technology with sealed for life ball bearings designed to operate continuously at a pre-set 'background' rate.

FAN

Is a 140 x 220mm centre mounted forward curved centrifugal fan.

FILTER

These units come as standard with a G4 ISO coarse 65% wrap around filter in accordance with EN779 standard ratings. The filter should conform to all European Union and US fire classification standards (e.g. DIN 53438-F1 and UL900-class 2) and be self-extinguishing. Higher filtration is available if required.

DIMENSIONS (MM)

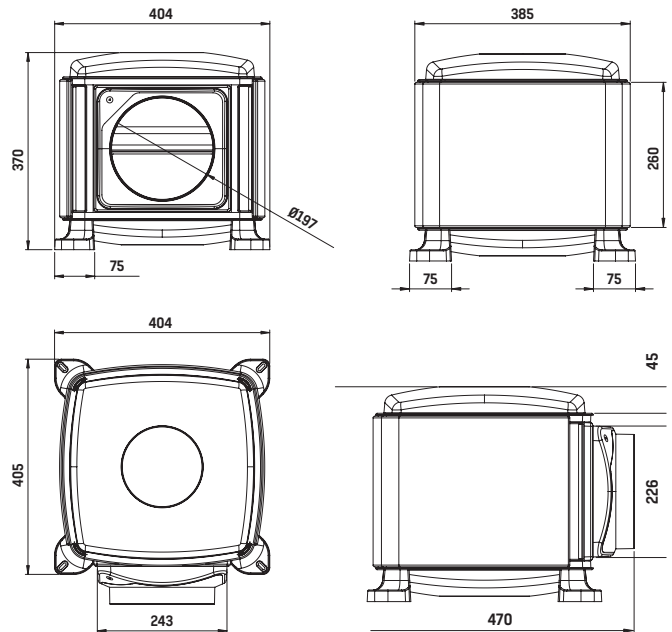

PERFORMANCE CURVE AT FREE AIR

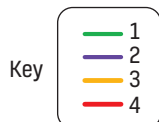
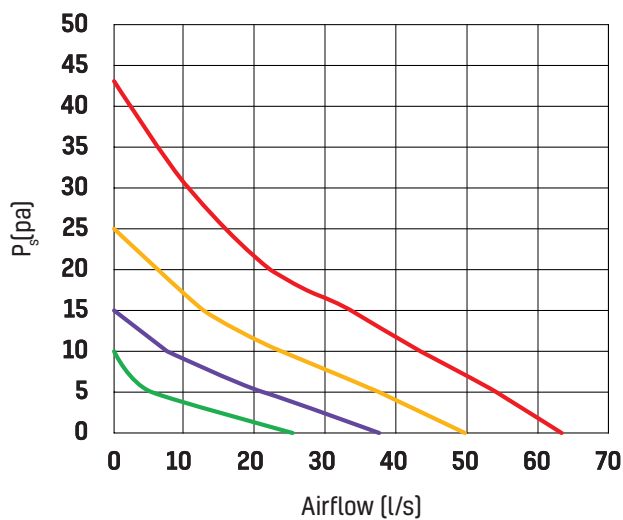

Performance curve results are measured at free air, based on the unit running below 19°C and exclude ancillaries